

# Schebler Carburetors

## Schebler Model S

**Action at Low Speeds.**—The Model S is an air valve carburetor having two air inlets. The fixed air opening is through the venturi (W) Fig. 1 and is very small, furnishing barely enough air to enable an engine to idle slowly. Due to the small opening through the venturi, the velocity of the air passing through it is very high, even when the engine is idling. This enables it to pick up gasoline at the nozzle (O) and atomize it thoroughly. Due to the venturi, the suction on the gasoline at the nozzle is quite strong, making it possible to control the mixture very accurately and to get positive and reliable action at low speeds.

**Capacity at High Speeds.**—The auxiliary air valve (C) Fig. 1 is closed for idling and wide open for full power. It is very large, making it possible to handle tremendous amounts of air at the smallest suction. This ability to handle either very large or very small air flows is what is referred to in the term "long range carburetor."

**Gasoline Passageway.**—The gasoline enters the float chamber through the valve (R) Fig. 1 and the level is governed by the float (J). After leaving the float chamber, the gasoline is governed by the gasoline needle (M) at the point (L). It then passes through the cross drill (N) into the nozzle (O) and on into the air stream through the venturi (W).

**How the Mixture Ratio is Maintained.**—The method of maintaining the correct fuel-to-air ratio is as follows: The motion of the air valve is transmitted to the needle valve lift lever (B) Fig. 1 which rotates about the fulcrum point (A), giving to the gasoline needle (M) a definite part of the air valve motion. Thus, the flow of gasoline will tend to vary in direct proportion to the air, no matter how much or how little air is being used.

The Model S carburetor is designed to give maximum power and maximum economy at the same adjustment. This may seem impossible at first but it is accomplished as follows: A very lean mixture is required to give the most miles per gallon while considerably more gasoline is needed for full power. When driving at medium speed or on a smooth road, comparatively little power is needed and economy and smooth performance are the important requirements. Under these conditions, the throttle will be only part way open and the fulcrum point (A) will be in the position corresponding to maximum economy. When full power is desired the throttle is opened wide. This will cause the cam, Fig. 5, to depress the cam tappet screw (D), thus moving the fulcrum point (A) Fig. 1 over toward the air valve, and lifting the gasoline needle (M). This will make the mixture a certain per cent richer just enough to change over from full economy to full power. These adjustments can be independently made on any engine so that they can both be exactly right. The carburetor can therefore be adjusted so as to give

maximum economy under ordinary driving conditions and still deliver full power and maximum acceleration when desired.

(T) Fig. 1 is placed at the required height so that any excess gasoline pumped into (S) will run back into the float chamber and will not be wasted. While necessarily large, the pump is therefore not wasteful.

The amount of gasoline required for acceleration varies with the size, shape and temperature of the intake manifold. The Model S pump can be adjusted to any manifold. The rate of delivering the extra gasoline can be changed according to the size of the metering hole (V) Fig. 1 and the total amount delivered according to the height of the overflow (T). The amount of extra gasoline used in acceleration is quite small but it makes the difference between positive action on the one hand and an uncertain and delayed response to the throttle on the other.

**The Dash Pot.**—The gasoline dash pot (I) Fig. 1 is used to prevent the fluttering of the air valve (C) when the engine is pulling hard at a low speed. Under these conditions, the fluctuations of pressure are slow but are of small magnitude so that the spring (E) is strong enough to hold the valve (F) firmly in place and prevent any fluttering. Suppose, however, that the car is driven at a high speed, the throttle closed for a moment and then suddenly opened again; an immediate response will be desired from the engine. Under these conditions, a heavy vacuum will be established in the manifold during the coasting which will be transferred to the air valve when the throttle is open. Under this heavy force, the spring (E) will collapse and the air valve will drop as though the dash pot were not there; allowing the engine to respond with a full thrust from the very first. The little valve (G) is provided to allow the air valve to close rapidly.

**Dash Control for Starting.**—The Model S has no choke. It delivers to the engine whatever air is needed and meters the required fuel into that air. When a very rich mixture is needed as in starting a cold engine, the dash control lever (F) Fig. 5 is pulled down by means of the wire (E). This will rotate the fulcrum lever (X) Fig. 1 about the shaft (Z) toward the air valve (C) and give the gasoline needle an initial lift from an increased percent of the motion of the air valve. The velocity of the air through the venturi (W) is ample to pick up and atomize whatever gasoline may pass through the nozzle (O), so that a mixture many times as great as normal may be effectively supplied to the manifold of the engine; and starting be made correspondingly easy. As the engine speeds up, the effect of the initial life of the needle will diminish so that the percent of excess gasoline will decrease but not disappear at high speeds. This corresponds to the requirements of an engine as a greater percent of excess gasoline is required to run a cold engine slowly than fast.

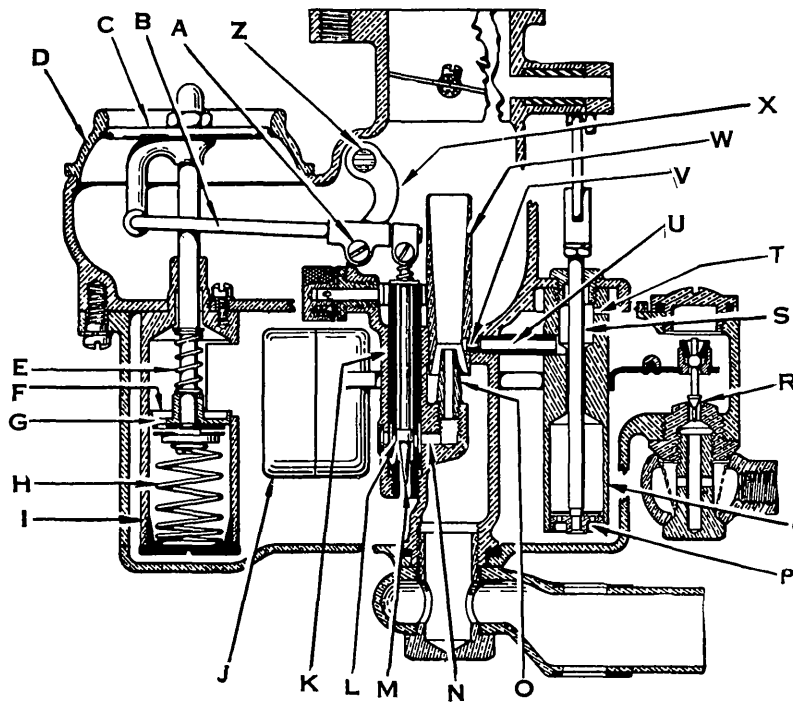

Fig. 1

Cross section view of Schebler Model S carburetor showing (A) lift lever fulcrum screw; (B) needle valve lift lever, (C) air valve, (D) air valve housing; (E) upper dash pot spring; (F) dash pot valve or piston; (H) lower dash pot spring, (I) dash pot housing; (I) float; (K) needle valve assembly; (O) main discharge nozzle; (P) accelerating pump piston, (Q) accelerating pump cylinder; (R) float valve assembly, (S) accelerating pump plunger or rod, (T) accelerating pump overflow passage; (U) accelerating pump cross passage; (V) accelerating pump cross passage discharge opening; (W) venturi; (X) lift lever fulcrum arm.

**Accelerating Pump.**—When the throttle is opened suddenly, a certain portion of the gasoline will lag behind the air. This will cause the mixture reaching the cylinders to be temporarily leaner than the accurately metered mixture leaving the carburetor. If the carburetor is adjusted lean for economy, this temporary impoverishment of the mixture would cause the engine to misfire were it not for the accelerating pump (Q) Fig. 1 which causes the mixture leaving the carburetor to be temporarily enriched during acceleration.

When the throttle is opened, the piston (P) Fig. 1 of the accelerating pump is raised lifting gasoline into the upper chamber (S). From here, the gasoline flows through the passageway (U) to the venturi (W) where it mixes with the air entering the carburetor. No gasoline at all will pass through (U) except immediately following an opening of the throttle; so that the accelerating pump acts only during periods of acceleration.

The capacity of the pump is large compared to the amount of gasoline used for acceleration. This is for a definite reason. When the throttle is opened, just a few degrees from the idling position at low speed, the engine will be running under full load and a full load charge of accelerating gasoline will be needed. The accelerating pump must therefore be able to deliver the full load charge of gasoline with just a few degrees of motion. On the other hand, no greater charge than this is needed when the throttle is opened wide. For this reason, an overflow passage (V), Fig. 1, is provided near the top of the pump cylinder to permit the excess gasoline to return to the carburetor bowl.

## DECELERATING DEVICE

The decelerating device, Fig. 2, increases the idling speed temporarily after the throttle has been returned to the idling position from a part or wide open throttle. In other words, if the car is driven along say at five miles per hour and the throttle is suddenly kicked open to 10 or 15 miles per hour or to any speed, then suddenly decelerated back to idle, the idling speed will be increased considerably for about 10 seconds when the decelerating device will close off allowing the motor to idle at the normal speed. This action gives a very positive idle under any condition.

The first carburetors with this decelerating device used the type shown on the print marked "first type," Fig. 2. After this first lot, the device was changed slightly and is as shown on the print showing the "second type."

Referring to the first type, the main points of the decelerating device are the cylinder or tube (6) and the plunger (5) Fig. 2. The tube fits in its bearing in the body and is held in place with a set screw (15). The upper end of the tube is bevelled so that by turning the tube the passage through hole (3) can be made large or small. The slot (18) is slightly below the gasoline level so that fuel can run into the tube. The slot (17) is at the body line and serves as an air opening so that no gasoline can be sucked up into the upper part of the tube. The cap (20) shuts off the lower end of the tube.

The upper end of the plunger (5) is cone shaped to fit in the shut off hole (2). The lower end is fitted with a ball valve which lets the piston drop rapidly but shuts off on the upward stroke and retards the rising of the plunger.

The action of the device is as follows: When the engine is idling normally, the plunger (5) is at the top of the cylinder and its cone shaped upper end closes off hole (2) thus closing off the idle by-pass through holes 1, 2 and 3. When the throttle is kicked open, the suction in holes 1 and 2 drop off, allowing the plunger to drop. When the throttle is again closed, the plunger does not rise instantly but travels slowly upward for a certain length of time before closing off. During this period, a by-passing occurs around the disc through holes 1, 2 and 3 and this by-passing speeds up the idle sufficiently to overcome any tendency to stall. When the plunger finally comes up and closes off the passageway, the manifold is sufficiently cleaned out so that the normal low idle will not die.

### First Type Decelerating Device

These devices have all been timed at the factory to close off in about 8 to 14 seconds. To check this time, turn off the motor then start the motor with the throttle closed and time the length of the increased speed from the instant the motor starts firing until the idle drops down to normal. Time this a number of times with the second hand of your watch or with a stop watch.

The normal idling speed should be set with the idle stop screw only after the low idle has been resumed.

The returned speed of the decelerating device can vary four or five seconds without causing any trouble.

If the motor refuses to return to the low idle, there is probably dirt in the device and the device should be taken out and thoroughly washed in clean gasoline. After it is in the carburetor, there is little chance for dirt to get into it.

To take out the decelerating device, remove the bowl and loosen up the screw (15) Fig. 2. Before doing this, mark the position of the tube in the body by scratching a line on both tube and body so that the tube will go back into the same position.

Remove the cap (20) and slip the plunger down as far as possible and then wash out the assembly with clean gasoline. The plunger in this first type cannot be taken all the way out.

Replace the cap (20) and tighten it down with a screwdriver; then replace the tube in the body in the same position as before and tighten set screw (16) just tight enough to hold the tube. Do not jam this screw; tighten the nut and lock washer and replace the bowl.

Try the decelerator for timing as explained above after you are sure that gasoline has filled the dash pot in the tube (6). The first few trials will be fast on account of air in the tube (6).

If the plunger cuts off the by-passing in less than 8 seconds, take off the bowl and turn the tube (6) counter-clockwise looking at the cap (20). If the plunger returns in more than 15 seconds, turn the tube (6) clockwise. For each trial, turn the tube about 1/16th of a complete revolution from the original position. Set the lock screw as explained above.

### Second Type Decelerating Device

In this type, the tube (6) is held in one position in the carburetor body, see Fig. 2. Since the screw (15) registers with a hole in the tube, the tube is also cut off square at the top.

The timing of this device is accomplished by turning the screw (22) which shuts off or opens up hole (3), depending upon which way it is turned. To slow the return to normal idle, turn the screw (22) counter-clockwise and to speed up the return, turn it clockwise. The return to normal idle as explained above, should occur in about 8 to 14 seconds.

If any trouble is encountered, take out the tube and plunger by removing the bowl and loosening up screw (15). Take off cap (20) and the plunger can be removed.

Clean the parts in clean gasoline and wipe off plunger and wipe out tube with a clean rag before reassembling. Replace cap (20) and replace the tube in the body, being sure that the pointed end of screw (15) registers with the holes in the tube (6). Also be sure that the valve seat (11) is tight in the plunger. Replace the bowl.

Time the device as explained above to close to normal idle in about 8 to 14 seconds.

## CARBURETOR ADJUSTMENT

### Schebler S Brass Bowl

**Idle Adjustment.**—Turn the idle adjusting knurl Fig. 3 to the right for a lean mixture and to the left for a rich mixture. To check the idle adjustment, warm up the motor thoroughly and by this we mean to have the motor hot; then close the

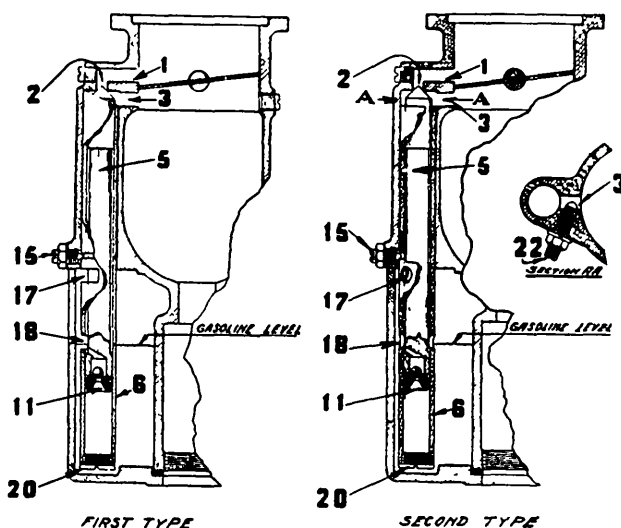

Fig. 2

Cross sectional view of the first and second types decelerating device used on Schebler S 1 1/2" carburetors. If difficulty is experienced with the motor idling fast on these models, clean the decelerating device as explained in the paragraphs under the heading "First Type Decelerating Device."

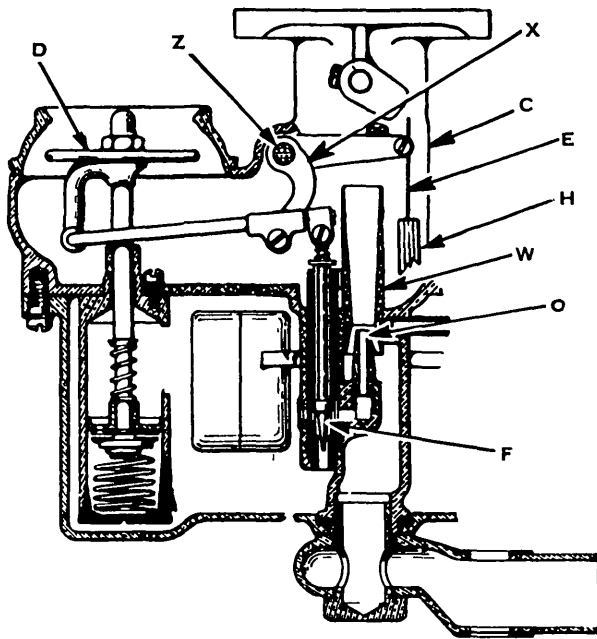

Fig. 3

*Schebler Model S Brass Bowl type of carburetor showing location of adjustment screws. Float valve seat is not a removable part.*

throttle, retard the spark all the way if the car has manual spark control, and then adjust idle stop screw so that the motor will not idle less than 5 miles per hour on the road. After the throttle has been adjusted so that the engine idles at the proper speed, then proceed to check the idle adjustment as follows: Turn the idle adjusting screw to the right (clockwise) turning slowly watching the motor fan at the same time and continue to turn in this direction which is the lean direction until the fan falters or in other words is not turning with a smooth constant motion. Just as soon as the fan falters, stop turning the idle adjustment to the right, lean, and from this point turn the idle adjustment back to the left or rich direction exactly six clicks for summer driving and eight to nine clicks for winter driving. Clicks can be felt while turning the idle adjusting knurl; this will give you an ac-

curate setting on the idle adjustment providing you follow out all of the instructions as outlined above.

**Range Adjustment.**—This adjustment is only effective in the driving range at speeds from 20 to 40 miles per hour and does not affect acceleration or hill climbing with wide open throttle.

The adjustment is made by turning the range adjusting screw (B) Fig. 3 to the left for a lean mixture and to the right for a rich mixture in the driving range.

To obtain the factory setting, screw the range adjusting screw (B) in or out so the head is flush with the bushing. If the range adjustment is changed, it will be necessary to readjust the idle mixture.

**Power Adjustment.**—This adjustment as shipped from the factory, ordinarily need not be changed. This adjustment is not sensitive to one turn in either direction and is only effective for wide open throttle running. In changing this adjustment, try it on a hill after each change for best results. In extreme cases, it may be necessary to furnish a leaner or richer mixture for wide open throttle position. The adjusting cam tappet screw is turned to the left (counter-clockwise) to give a richer mixture and turned to the right (clockwise) to give a leaner mixture.

With throttle wide open, adjust the cam tappet screw until there is about  $\frac{1}{8}$ " to  $\frac{5}{32}$ " space between the dash control lever (P) Fig. 3 and the end of the range screw (B).

**Schebler S Die Cast Bowl**

**Idle Adjustment.**—Turn the idle adjusting knurl Fig. 4 to the right for a lean mixture and to the left for a rich mixture. To check the idle adjustment, warm up the motor thoroughly and by this we mean to have a hot motor. Then close the throttle, retard the spark all the way if the car has manual spark control and then adjust idle stop screw so that motor will not idle less than five miles per hour on the road. After you have the proper idle engine speed, then proceed to check the idle adjustment as follows: Turn the idle adjusting screw to the right (clockwise) turning slowly,

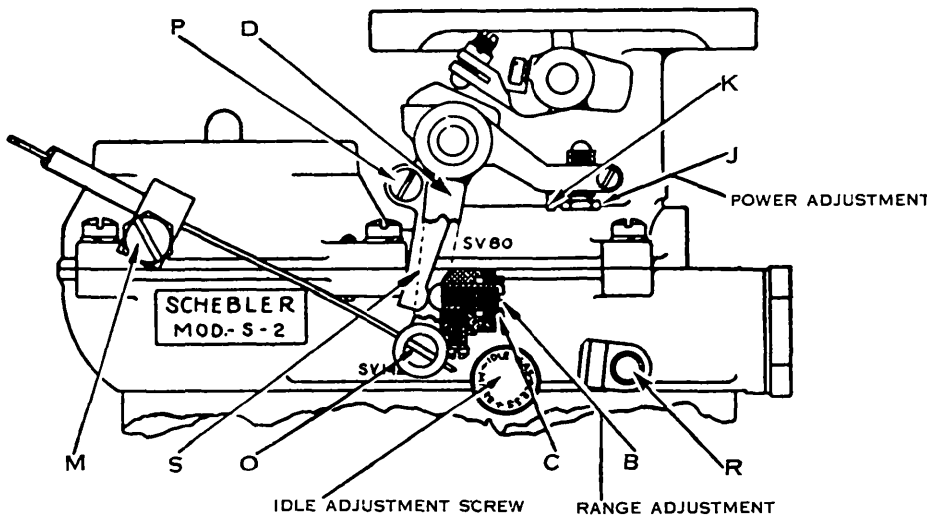

Fig. 4

*Schebler Model S with Die Cast Bowl showing the three adjustments. On regular type carburetors (those having Brass Cast Bowls) the float valve seat is not a removable part but is machined in the main bowl casting. On Die Cast Bowl types the float valve and seat are furnished as a separate assembly.*

watching the motor fan at the same time and continue to turn in this direction, which is the lean direction, until the fan falters or in other words, is not turning with a smooth, constant motion. Just as soon as the fan falters, stop turning the idle adjustment to the right (lean) and from this point turn the idle adjustment back to the left or rich direction exactly six clicks for summer driving and eight to nine clicks for winter driving. Clicks can be felt while turning the idle adjusting knurl. This will give you an accurate setting on the idle adjustment providing you follow out all of these instructions just as they have been outlined above.

**Range Adjustment.**—This adjustment is only effective in the driving range at speeds from 20 to 40 miles per hour and does not effect acceleration or hill climbing with wide open throttle.

The adjustment is made by turning the range adjusting screw (B) Fig. 4 to the left for a lean mixture and to the right for a rich mixture in the driving range.

This adjustment as shipped from the factory will usually be found to be best unless a lean or richened mixture is necessary at speeds from 20 to 40 miles per hour.

To obtain the factory setting, screw the range adjustment screw (B) in or out so the head is flush with the bushing (C). If the range adjustment is changed, it will be necessary to readjust the idling mixture.

**Power Adjustment.**—Extensive research indicates that the carburetor will give the best mixture for maximum power on the hills or at high speeds when the power screw (J) Fig. 4 is flush with the pin (K) in high altitudes, however, more power may be obtained by leaning up on the power mixture—turning (J) to the left (counter-clockwise) three to five turns.

**Accelerating Pump Adjustment.**—You will note a small lever on the accelerating pump which governs the amount of accelerating gas. This lever should be in the raised position for winter giving a larger amount of extra gas for acceleration. In the summer, this lever should be pushed down because in summer you do not need as much gas for quick acceleration.

### Schebler S Stamped Bowl

**Idle Adjustment.**—Turn the idle adjusting knurl (A) Fig. 5 to the right for a lean mixture and to the left for a rich mixture. To check the idle adjustment, warm up the motor thoroughly and by this we mean to have a hot motor. Then close the throttle, retard the spark all the way if car has manual spark control and then adjust idle stop screw so that motor will not idle less than five miles per hour on the road. After you have made the proper idle adjustment so that the motor runs at the correct speed, then proceed to check the idle adjustment as follows: Turn the idle adjusting screw (A) Fig. 5 to the right (clockwise) turning slowly, watching the motor fan at the same time and con-

tinue to turn in this direction which is the lean direction until the fan falters or in other words is not turning with a smooth constant motion. Just as soon as the fan falters, stop turning the idle adjustment (A) to the right (lean) and from this point turn the idle adjustment back to the left or rich direction exactly six clicks for summer driving and eight to nine clicks for winter driving. Clicks can be felt while turning the idle adjusting knurl (A). This will give you an accurate setting on the idle adjustment providing you follow out all of these instructions just as we have outlined them.

**Range Adjustment.**—See Range Adjustment for Schebler Model S Brass Bowl.

**Power Adjustment.**—See Power Adjustment for Schebler Model S Brass Bowl.

### Schebler S Duplex

**Idle Adjustment.**—The Duplex carburetor has two idle adjustment (A) and (E) Fig. 6. Before making any carburetor adjustments, warm up the motor to average driving temperature. Both adjustments (A) and (E) turn in the same direction for rich and for lean. Turning these adjustments to the right (clockwise) makes the mixture leaner and to the left (counter-clockwise) makes the mixture richer.

The Duplex carburetor has two throttle openings into the manifold and the throttle opening and idle adjustment next to the motor always controls the four center cylinders numbers 3-4-5-6; the throttle opening and idle adjustment of the carburetor which is on the outside next to the hood of the car always governs the two front and two back cylinders numbers 1-2-7-8.

To adjust the inside idle adjustment next to the motor, disconnect spark plug wires numbers 1-2-7-8 and ground them some place on the motor head. This leaves the four center cylinders numbers 3-4-5-6 operating which are governed by inside idle adjustment. Run idling adjustment screw (A) in a little way in order to get a slightly faster idle

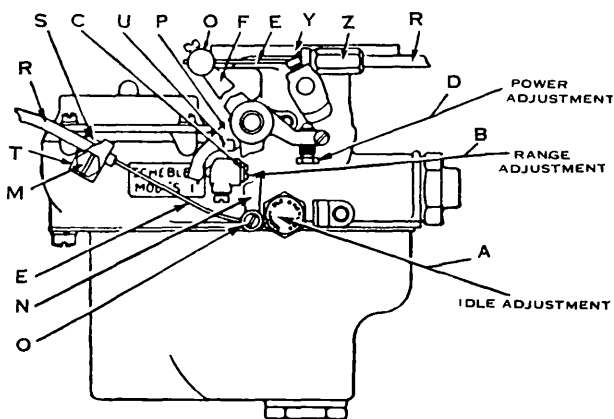

Fig. 5

*Schebler Model S Stamped Bowl showing three adjustments. On regular type carburetors (those having Brass Cut Bowl) the float valve seat is not a removable part but is machined in the main bowl casting. On Stamped Bowl type float valve and seat are furnished as a separate assembly*

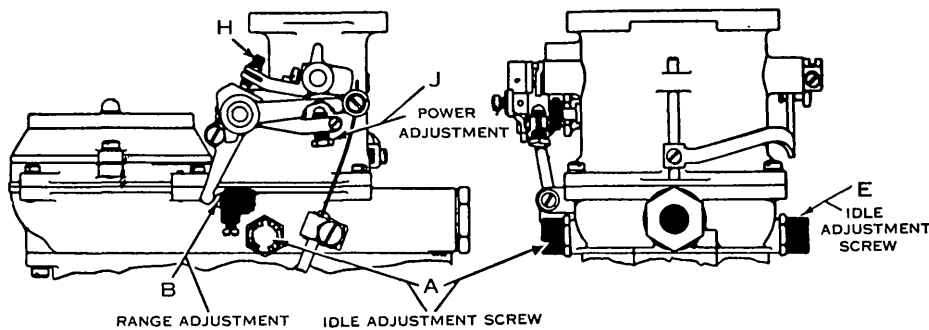

Fig. 6

Schebler Model S Duplex showing two idle and one power adjustment. The throttle opening and idle adjustment next to the motor controls cylinders numbers 3-4-5-6; the outside throttle opening and idle adjustment controls cylinders numbers 1-2-7-8.

speed which is necessary when checking four cylinders at a time. Retard the spark and depress the air valve of the carburetor  $1/32''$  to  $1/16''$ . If the adjustment is lean on the four center cylinders numbers 3-4-5-6, the motor will die immediately. If adjustment is too rich, the motor will speed up. When adjustment is just right, you should be able to depress the air valve  $1/32''$  to  $1/16''$  and the motor should continue to turn over 2 or 3 revolutions and then start to quit.

To adjust the outside idle adjustment, put the spark plug wires back on numbers 1-2-7-8 plugs and remove wires from numbers 3-4-5-6 and ground them. You are then ready to check the outside idle adjustment by depressing the air valve the same as described above.

After checking the two idle adjustments individually, connect up all spark plug wires so all eight cylinders will fire and then make a double check by depressing the air valve of the carburetor the same as you did when checking four cylinders at a time. Before making your final check with all eight cylinders firing, check the engine idle speed setting the idle stop screw (H) so that the engine will idle 5 to 6 miles per hour on the road. In making the final check by depressing the air valve, if you find the job a little rich or lean with all eight cylinders hooked up, turn both idle adjustments in the same directions rich or lean to correct this, turning each one only one or two clicks at a time and then recheck by depressing the air valve of the carburetor.

**Range Adjustment.**—This adjustment is only effective in the driving range at speeds from 20 to 40 miles per hour and does not affect acceleration or hill climbing with wide open throttle.

The adjustment is made by turning the range adjusting screw (B) Fig. 6 to the left for a lean mixture and to the right for a rich mixture in the driving range.

This adjustment as shipped from the factory will usually be found to be best unless a lean or richened mixture is necessary at speeds from 20 to 40 miles per hour.

To obtain the factory setting, screw the range adjusting screw (B) in or out so the head is flush with the bushing. If the range adjustment is changed, it will be necessary to readjust the idle adjustments.

**Power Adjustment.**—The carburetor will give the best mixture for speed and maximum power on the hill when the bottom of the head of the power screw (J) Fig. 6 is setting so that it measures  $7/32''$  to the arm that holds screw (J). On the later Duplex carburetor, there is a small pin located at the side of the screw (J) and the original factory setting is to have the bottom of the head on screw (J) flush with the bottom of the pin. In high altitudes, more power can be obtained by leaning up on the power mixture—turning screw (J) to the left (counter-clockwise) 3 to 5 complete turns. Turning screw (J) to the right richens the power mixture.

## CARBURETOR

### SPECIFICATION DIAGNOSIS

**Schebler Model S.**—There are three points to be considered in the specification information for Schebler Model S carburetors; namely, needle valve assembly (B) Fig. 6A, air valve spring (A) and cross passage (E).

**Needle Valve Assembly.**—The amount of gasoline that is supplied to the main nozzle is determined by the taper of the needle valve. The ta-

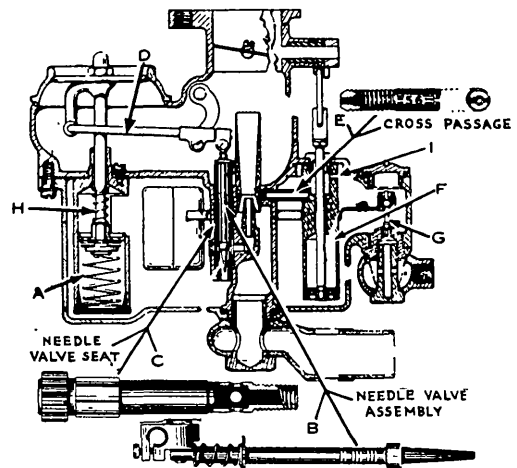

Fig. 6A

Cross sectional view of Schebler Model S carburetor showing (A) air valve spring; (B) needle valve complete; (C) needle valve seat; (D) needle valve lift lever; (E) accelerating pump metering or cross passage; (F) accelerating pump cylinder; (G) float needle valve assembly.

per of the needle is graduated in degrees and each needle valve is numbered by rings on the body of the needle as shown in Fig. 6A. A greater taper of the needle valve would mean a richer mixture and a straighter taper would mean a leaner mixture. It should be borne in mind, however, that while the needle taper is graduated in degrees, the rings on the body of the valve do not indicate the number of degrees of taper. The following table contains the needle valve number, part number, taper angle and number of rings found on the body of the valve.

**Diagnosis, Needle Valve Taper too Great.**—If the needle valve taper is too great, the car owner will probably complain of poor gasoline mileage.

A slight change in favor of a richer mixture cannot be noticed in the performance of the car since there is so great a range between the point of where the car will operate efficiently and where the mixture would necessarily need to be so rich that the car would load or give other indications other than poor gasoline mileage.

**Diagnosis, Needle Valve Taper Too Straight.**—If the needle valve taper is too straight, the mixture may be too lean and cause the motor to surge. The car would lack power on a hill with a tendency to hunt.

If trouble is experienced with a Schebler Model S carburetor and the symptoms indicate a defective needle valve action, check to see that the fulcrum arm (D) Fig. 6A is not worn causing the needle valve fulcrum lever to stick. This condition generally causes a too rich mixture.

### Needle Valve Assemblies

The following table contains part number, needle valve assembly number and taper in degrees of needle valve used in Schebler Model S carburetors.

Part	No.	Taper Angle	No. of Rings
X1712	1	5° 32'	1
X1712	2	5° 8'	2
X1712	3	5° 20'	3
X1712	4	4° 40'	4
X1712	5	5°	5
X1712	6	6°	6
X1712	7	6° 26'	7
X1712	8	7° 37'	8
X1712	9	8° 34'	9
X1712	10	7°	10
X2205	1	6°	1
X2205	2	8°	2
X2205	3	10° 20'	3
X2205	4	11° 52'	4

**Air Valve Spring.**—The air valve spring is located in the dash pot as shown at (A) Fig. 6A and is for the purpose of controlling the action of the air valve.

If the air valve spring weakens in service, the tension against the air valve piston will not be great enough and a tendency toward a lean mixture will result. If a condition of weak air valve spring is encountered, replace with a new spring. These air valve springs are graduated to a certain tension and if they are stretched or distorted in any way, the balance of the carburetor may be disturbed.

The correct operation of the carburetor is largely dependent upon the correct tension of the spring (A). A table of air valve spring sizes will be found below.

### Air Valve Spring

The following table lists the part assembly number, spring number, spring gauge size and number of coils for each model of Schebler Model S carburetors.

Part No.	No. of Coils	Length	Used On	Gauge
48S	12	2 7/8" to 3 3/8"	1 1/4" S	14
48I	8 1/2	2 1/4" to 2 3/4"	1 1/2" S	20
48R	8	2 1/4" to 2 3/4"	1 1/2" S	16
48D	10	2" to 2 1/8"	1 1/4" S	16
48J	10	2" to 2 3/8"	1 1/4" S	17
48U	10 1/2	2 3/8" to 3 1/8"	1" to 1 1/4" S	15
48CC	9 1/2	2 1/2" to 3"	1 1/4" S	20
48Y	10 1/2	2 3/4" to 3 1/8"	1" S	18
48X	10	2 1/8" to 2 3/8"	1 1/2" S	16
48BB	11	2 1/8" to 2 3/8"	1 1/4" S	16
48E	16	6 1/2"	2 1/2" S	18
48DD	9	2 1/2" to 2 3/4"	1 3/4" S	20
48FF	16	6 1/2"	2" to 2 1/4" S	20

**Cross Passage.**—The cross passage connecting the accelerating pump chamber with the venturi as shown at (E) Fig. 6A and control the amount of gasoline admitted to the venturi during acceleration. Pump cross passages are made in drill sizes and the number of the passage is stamped on the side of the cross passage body. In the table below, the length of the cross passage, size number and drill size in thousandths of an inch is given.

**Diagnosis, Accelerating Pump Cross Passage too Small.**—If the accelerating pump cross passage (E) Fig. 6A is too small, the car may have a flat spot on acceleration. This condition will generally be indicated by a popping back through the carburetor due to a lean mixture.

The proper procedure for locating a cross passage of the wrong size in cases where the cross passage is thought to be too small, is to increase the size approximately two drill sizes at a time until the motor just smooths out on acceleration.

**Diagnosis, Accelerating Pump Cross Passage too Large.**—If the accelerating pump cross passage is too large, the car will have a tendency to Roll and load on fast acceleration. This trouble is generally caused by someone unfamiliar with the proper calibration procedure drilling out the cross passage or replacing it with a cross passage that is too large. To correct this condition, try a smaller cross passage.

**Needle Valve Seat.**—When installing a new needle valve seat (C) Fig. 6A, screw the seat in until the gears stand at approximately the center of the pinion.

Table of Cross Passage Sizes

The following table contains the part number, length, size number, drill size in thousandths of an inch and model of Schebler carburetor on which the cross passages are used.

Part	Length	Size No.	Drill	Used On
S1446	1/8"	52	.0635"	1" Model "S"
S1446A	1/8"	54	.055"	1" " "S"
S1446B	1/8"	56	.0165"	1" " "S"
S1446C	1/8"	58	.042"	1" " "S"
S1446D	1/8"	60	.010"	1" " "S"
S1446E	1/8"	50	.070"	1" " "S"
S1446F	1/8"	70	.027"	1" " "S"
S1199	1 1/16"	52	.0635"	1 1/2" " "S"
S1199A	1 1/16"	54	.055"	1 1/2" " "S"
S1199B	1 1/16"	56	.0465"	1 1/2" " "S"
S1199C	1 1/16"	58	.042"	1 1/2" " "S"
S1199D	1 1/16"	60	.010"	1 1/2" " "S"
S1199E	1 1/16"	50	.070"	1 1/2" " "S"
S1199F	1 1/16"	48	.076"	1 1/2" " "S"
S1586	1 1/16"	52	.0335"	1 1/2" Dis Cast "S"
S1586A	1 1/16"	54	.055"	1 1/2" " "S"
S1586B	1 1/16"	56	.0465"	1 1/2" " "S"
S1586C	1 1/16"	58	.042"	1 1/2" " "S"
S1586D	1 1/16"	60	.010"	1 1/2" " "S"
S1586E	1 1/16"	50	.070"	1 1/2" " "S"
S1586F	1 1/16"	48	.076"	1 1/2" " "S"
S1324	1 1/16"	50	.070"	1 1/2" " "S"
S1324A	1 1/16"	48	.076"	1 1/2" " "S"
S1324B	1 1/16"	52	.0635"	1 1/2" " "S"
S1324C	1 1/16"	54	.055"	1 1/2" " "S"
S1324D	1 1/16"	56	.0465"	1 1/2" Model "S"
S1508	1 1/16"	54	.055"	1 1/2" " "S"
S1508A	1 1/16"	50	.070"	1 1/2" " "S"
S1508B	1 1/16"	52	.0335"	1 1/2" " "S"
S1508C	1 1/16"	56	.0465"	1 1/2" " "S"
S1652	1 1/16"	54	.055"	Special 1 1/2"
S1652A	1 1/16"	50	.070"	" 1 1/2"
S1652B	1 1/16"	52	.0635"	" 1 1/2"
S1652C	1 1/16"	56	.0465"	" 1 1/2"
S1578	1 1/16"	50	.070"	" 1 1/2"
S1775	1 1/16"	52	.0635"	" 1 1/2"
S1767	1 1/16"	52	.0635"	2-2 1/2" Model "S"
S1767A	1 1/16"	54	.055"	"
S1767B	1 1/16"	56	.046"	"
S1767C	1 1/16"	58	.042"	"
S1767D	1 1/16"	60	.040"	"
S1767E	1 1/16"	50	.070"	"
S1767F	1 1/16"	48	.076"	"

Schebler Model U

**An Air Valve Carburetor.**—The Model U is an air valve carburetor, having two air inlets. Referring to Fig. 7, the auxiliary air valve (Y) is closed for idling, and wide open for full power. It is held in a closed position by the spring (H) and will not open until the suction in the body of the carburetor is great enough to compress the spring. The spring (H) is just strong enough to insure good atomization of the fuel. The pressure required to open the valve (Y) to its wide open position is very little greater than that required to barely crack it from its seat. Thus positive action at low speed is assured with the greatest possible capacity at high speed.

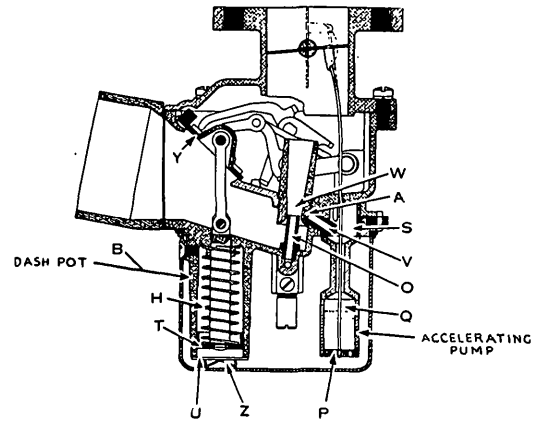

Fig. 7

Cross section of Model U Schebler carburetor showing (H) air valve spring; (O) main gasoline nozzle; (P) accelerating pump piston; (Q) accelerating pump assembly; (T) air valve piston; (U) dash pot release valve; (V) cross passage to venturi; (VI) cross passage metering hole; (W) venturi; (Y) air valve; (Z) dash pot cylinder release valve spring.

**Action at Low Speed.**—The fixed air opening is through a venturi (W) past the nozzle (O). The air for the venturi passes through the same opening at the intake to the carburetor as the air which goes past the air valve (Y). As it passes the nozzle (O) it picks up the proper amount of fuel and atomizes it, delivering it to the motor. As the air valve (Y) opens, the air passing this valve mixes with the mixture delivered from the venturi (W). The fixed air opening through the venturi (W) has two important parts to play. When the air valve (Y) is clamped down in the starting position and the needle valve (M, Fig. 8) raised to the starting position, a very rich mixture is delivered out of the venturi (W, Fig. 7), which produces a good starting condition. When the carburetor is operating normally, the fixed air opening through the venturi (W, Fig. 7) creates a high air velocity past the nozzle (O) and the fuel delivered out of the nozzle is torn up and atomized so that good low speed operation is obtained.

**The Gasoline Passageway.**—The gasoline enters the float chamber through the valve (R, Fig. 9), and the level is governed by the float (J). After leaving the float chamber, it is governed by the gasoline needle (M, Fig. 8). It then passes through the cross-drill (N, Fig. 10), into the nozzle (O, Fig. 7), and on into the air stream through the venturi (W).

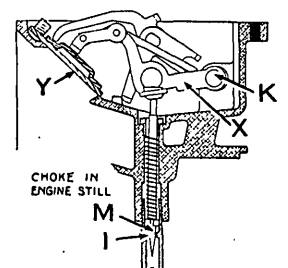

Fig. 8

Cross section of air valve and control levers Model U Schebler carburetor; (K) air valve lift lever fulcrum; (M) needle valve; (X) air valve life lever; (Y) air valve.